



SDU HORIZONTAL HANDING CONFIRMATION

SO NUMBER (INTERNAL USE)		WO NUMBER (INTERNAL USE)	
------------------------------------	--	------------------------------------	--

SPLIT DUCTED UNITS (SDU IDH)

MODELS	S024-095IHR3SA-
GENERAL	This document details the airside configurations available on 024-095 models.
SOURCING	Standard configuration is Front Supply /Rear Return. Optional airside configurations to be specified at time of order.
HOW TO USE THIS DOCUMENT	<ol style="list-style-type: none"> 1. Circle the required supply air outlet. 2. Complete the information at the bottom of this document and return to your APAC representative.

FS/RR – FRONT SUPPLY / REAR RETURN	TS/RR – TOP SUPPLY / REAR RETURN
---	---

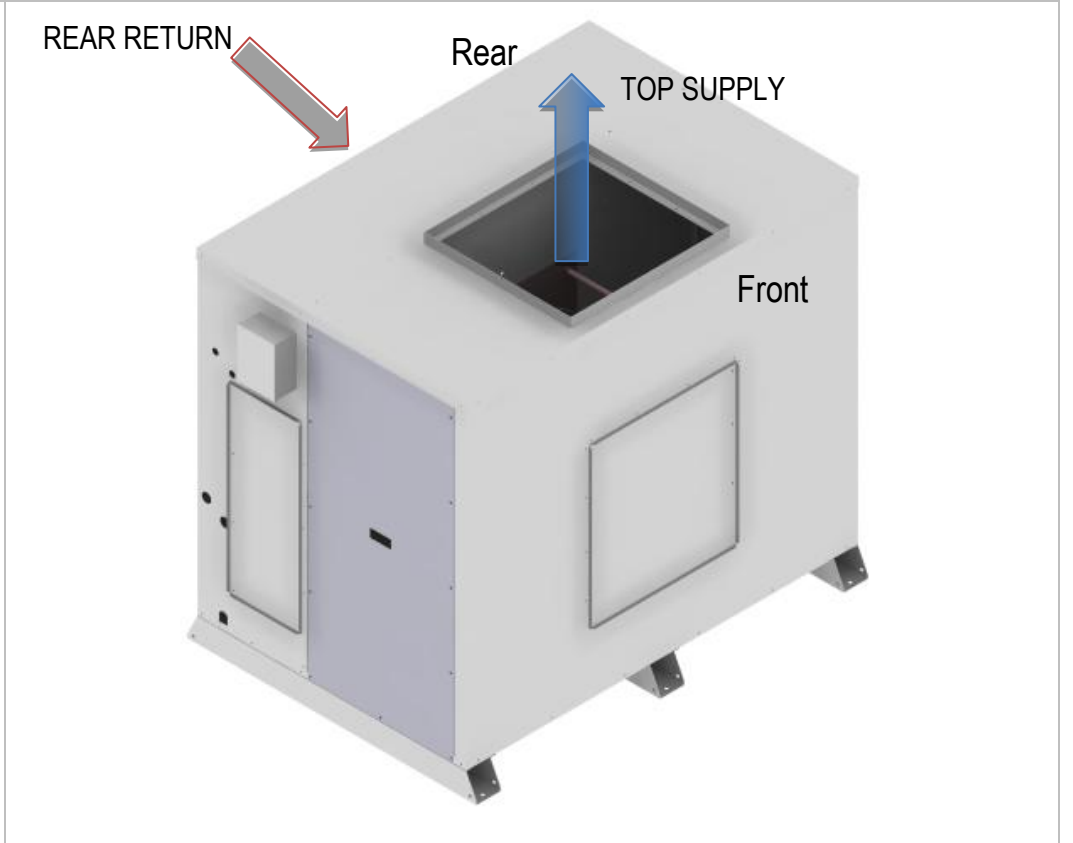
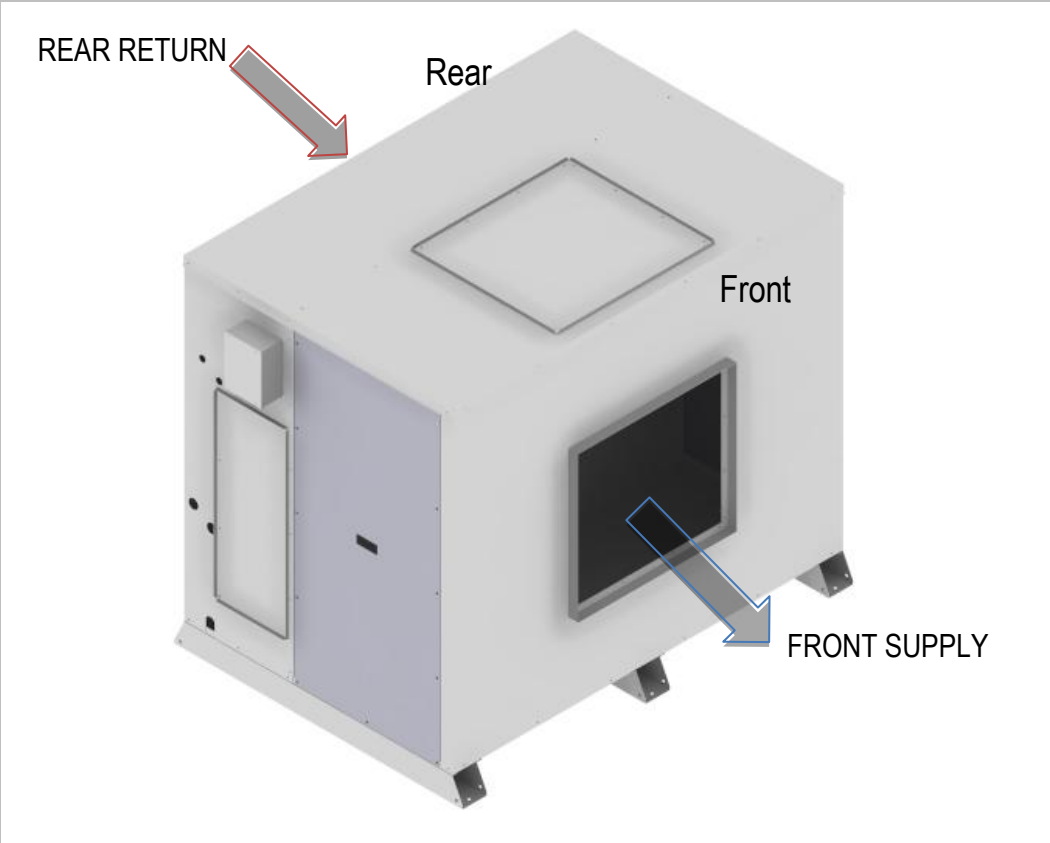

CUSTOMER TO COMPLETE AND RETURN

CUSTOMER	PROJECT	UNIT REF	NAME / SIGN	DATE

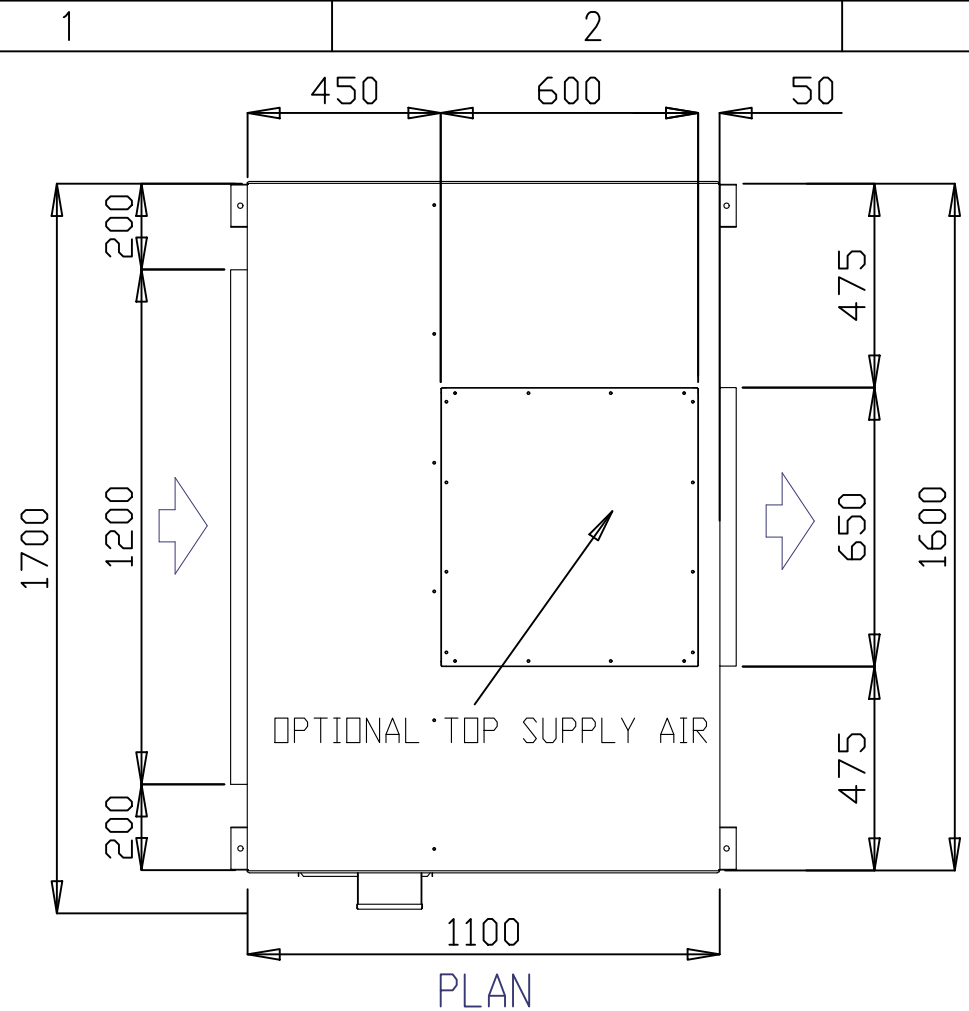

PLAN

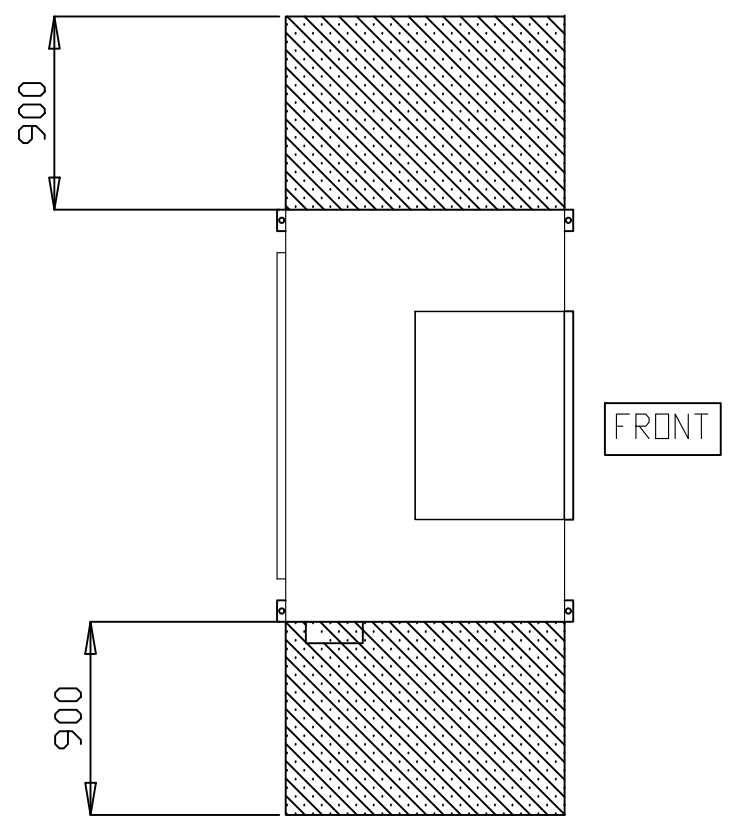

CLEARANCE DETAIL

- NOTES :
1. DRAWING REFLECTS A HORIZONTAL FAN COIL UNIT
 2. GAS, DRAIN & ELECTRICAL CONNECTIONS ON SAME SIDE
 3. ELECTRICAL CABLE ENTRY 25mm ϕ .
 4. CONDENSATE DRAIN OUTLET 25.4mm ϕ
 5. ACCESS DOORS ON BOTH SIDES
 6. OPTIONAL TOP SUPPLY CONFIGURABLE ON SITE
 7. REFER TO INSTALLATION AND OPERATIONAL MANUAL FOR PIPE SIZING

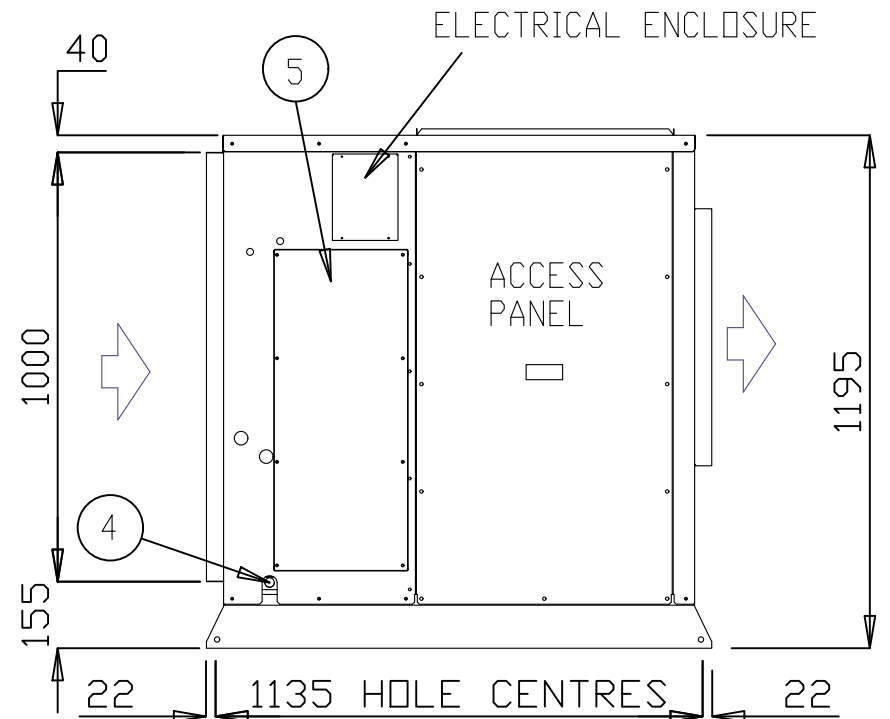

ELEVATION

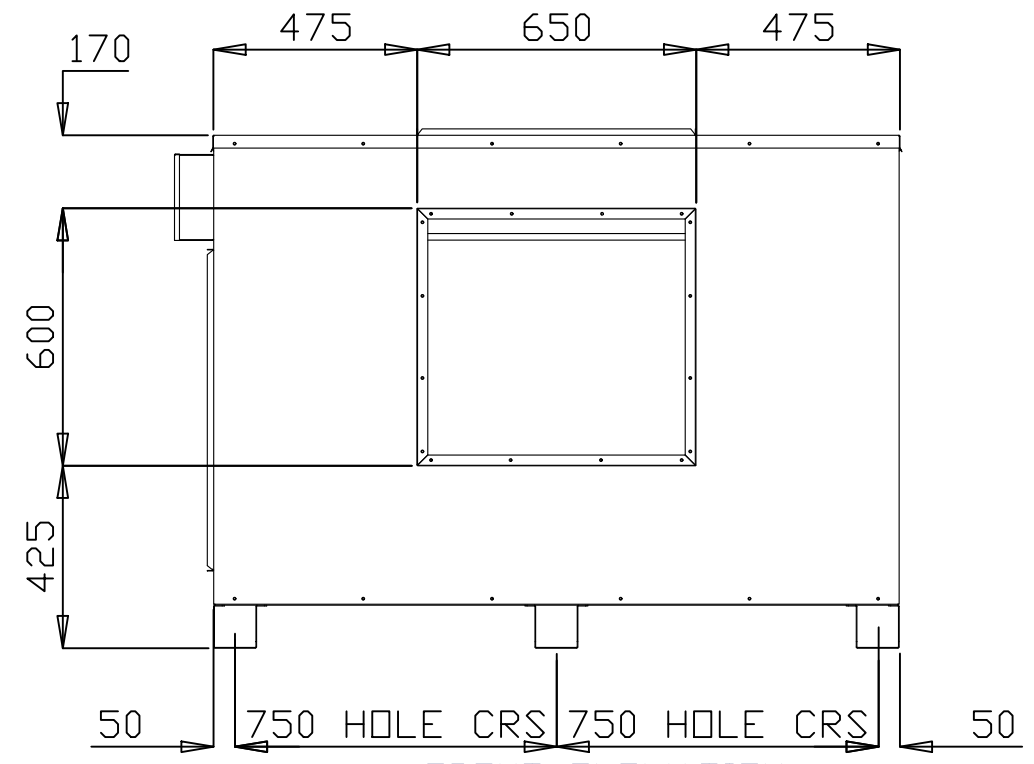

FRONT ELEVATION

- ALL DIMENSIONS IN mm.
- GENERAL TOLERANCE ± 1 mm.
- DO NOT SCALE DRAWING.
- MASTER DRAWINGS ARE HELD ELECTRONICALLY. ANY COPY IS DEEMED UNCONTROLLED AND THEREFORE NOT NECESSARILY THE LATEST REVISION.
- ALL INFORMATION REMAINS THE PROPERTY OF THE COMPANY.

GENERAL ARRANGEMENT

S024IHR3SA- S030IHR3SA- S035IHR3SA- S040IHR3SA- S045IHR3SA-

www.apacair.com.au

ABN: 74 005 138 769

	REVISION					REVISED NAMEPLATE WITH APAC DETAILS				
	DRAWN		MT	DRAWING No.		A4				
	DATE		11.02.14	<p>GAD0012</p>						
	SCALE		N.T.S.							
CHECKED		HA	APP'D.	CM	REV.	D				

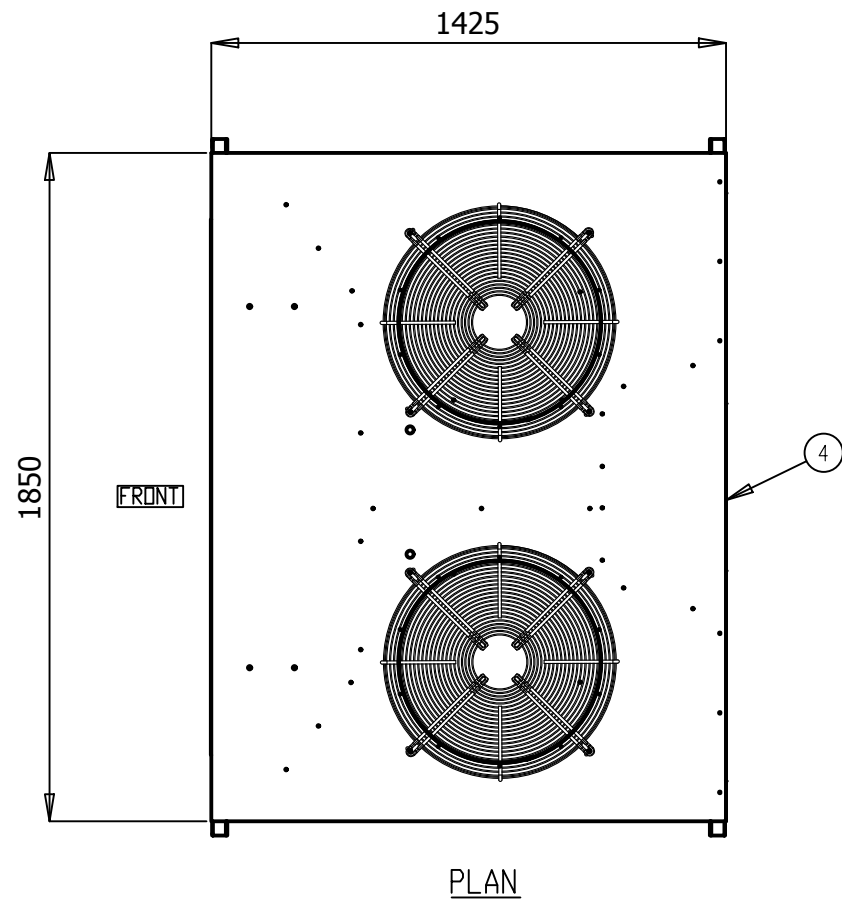

- NOTES:
1. GENERAL ARRANGEMENT OF A OUTDOOR SPLIT AIR COOLED VERTICAL UNIT
 2. POWER AND FIELD CABLE ENTRIES, 1 x 32 ϕ AND 2 x 25 ϕ
 3. ELECTRICAL PANEL LOCATED BEHIND SERVICE ACCESS
 4. FIELD PIPE CONNECTIONS
 5. UNIT BASE 4 x 16 ϕ FIXING POINTS
 6. UNIT HAS 4 x 20 ϕ LIFTING POINTS
 7. REFER TO INSTALLATION AND OPERATIONAL MANUAL FOR PIPE SIZING

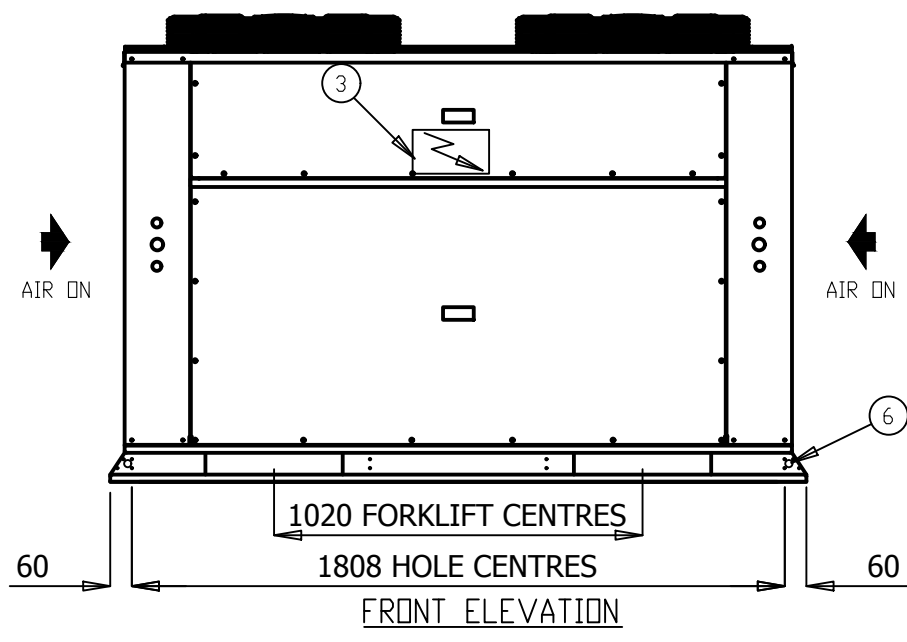
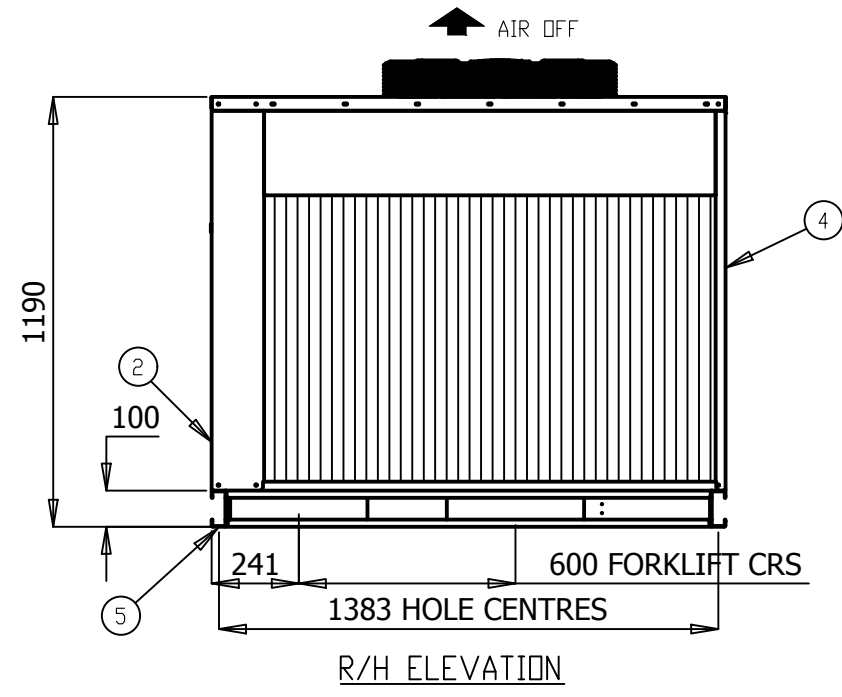
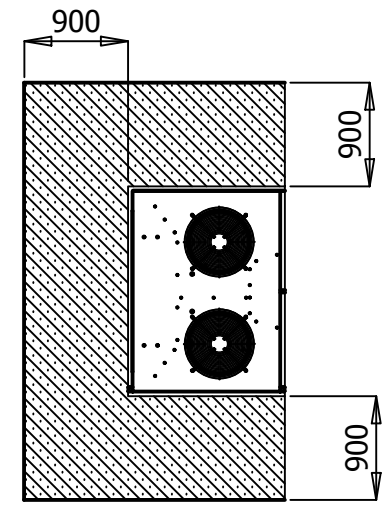

- ALL DIMENSIONS IN mm.
- GENERAL TOLERANCE ± 1 mm.
- DO NOT SCALE DRAWING.
- MASTER DRAWINGS ARE HELD ELECTRONICALLY. ANY COPY IS DEEMED UNCONTROLLED AND THEREFORE NOT NECESSARILY THE LATEST REVISION.
- ALL INFORMATION REMAINS THE PROPERTY OF THE COMPANY.

GENERAL ARRANGEMENT

S0240VR3SA- S0300VR3SA- S0350VR3SA- S0400VR3SA- S0450VR3SA-

www.apacair.com.au

ABN: 74 005 138 769

	REVISION					REVISED NAMEPLATE WITH APAC DETAILS				
	DRAWN		MT		DRAWING No.			A4		
	DATE		24.08.14		GAD0028					
	SCALE		N.T.S.							
CHECKED		HA		APP'D.		CM		REV. D		

TECHNICAL DATA SHEET

MODEL NUMBER	Indoor	S024IHR3SA-	S030IHR3SA-	S035IHR3SA-	S040IHR3SA-	S045IHR3SA-	
	Outdoor	S024OVR3SA-	S030IHR3SA-	S035OVR3SA-	S040OVR3SA-	S045OVR3SA-	
MEPS REGISTRATION NUMBER		AAC3231	AAC3235	AAC3273	AAC3232	AAC3234	
OUTDOOR SECTION	CAPACITY						
	Cooling	kW TOTAL*	25.15	31.02	34.13	39.78	45.27
		kW SENSIBLE*	19.39	25.97	28.12	32.42	36.62
		EER (kW / ikW)*	3.59	3.60	3.44	3.40	3.27
	Heating	kW TOTAL	23.80	30.20	33.60	40.10	43.50
		COP	3.66	3.60	3.78	3.61	3.71
	CAPACITY STEPS (%)		50/100	50/100	50/100	50/100	50/100
	COMPRESSOR						
	TYPE		SCROLL	SCROLL	SCROLL	SCROLL	SCROLL
	STARTER TYPE		D.O.L (Opt Soft/Start)	D.O.L (Opt Soft/Start)	D.O.L (Opt Soft/Start)	D.O.L (Opt Soft/Start)	D.O.L (Opt Soft/Start)
	PHASE		3Ø	3Ø	3Ø	3Ø	3Ø
	No. OFF		2	2	2	2	2
	PROTECTION DEVICES HP SWITCH, LP SWITCH, MOTOR OVERLOAD'S						
	ALL COMPRESSORS HAVE CRANKCASE HEATER						
	FAN						
	TYPE		AXIAL	AXIAL	AXIAL	AXIAL	AXIAL
	ikW (MAX INPUT)		0.39	0.39	0.39	0.60	0.60
	PHASE		1Ø	1Ø	1Ø	1Ø	1Ø
	No. OFF		2	2	2	2	2
	FAN SPEED CONTROL		VARIABLE SPEED	VARIABLE SPEED	VARIABLE SPEED	VARIABLE SPEED	VARIABLE SPEED
	HEAT EXCHANGER						
	TYPE		PLATE FIN COIL	PLATE FIN COIL	PLATE FIN COIL	PLATE FIN COIL	PLATE FIN COIL
	NOM. AIRFLOW l/s		-	-	-	-	-
	REFRIGERANT SYSTEM						
	TYPE		R410A				
CHARGE PER CIRCUIT (KG)		3.95	5.3	5.7	7.3	6.8	
No. OF CIRCUITS		2	2	2	2	2	
REFRIGERANT CONTROL		TXV					
ALL SYSTEMS INCLUDE DRIERS & SIGHT GLASSES							
DIMENSIONS							
H X W X D (mm)		1190 x 1850 x 1425					
WEIGHT							
OPERATING KG		362	382	389	414	414	
SHIPPING KG		366	386	393	418	418	
ELECTRICAL							
POWER		415v / 3Ø / 50hz					
FLA/RLA (Amps)		19.6/12.9	24.2/14.8	27.2/18.0	35.2/19.4	35.2/21.1	
INDOOR SECTION	FAN						
	TYPE		EC PLUG	EC PLUG	EC PLUG	EC PLUG	EC PLUG
	ikW (MAX INPUT)		2.73	2.73	2.73	3	3
	PHASE		3Ø	3Ø	3Ø	3Ø	3Ø
	No. OFF		1	1	1	1	1
	FAN SPEED CONTROL		VARIABLE SPEED	VARIABLE SPEED	VARIABLE SPEED	VARIABLE SPEED	VARIABLE SPEED
	HEAT EXCHANGER						
	TYPE		PLATE FIN COIL	PLATE FIN COIL	PLATE FIN COIL	PLATE FIN COIL	PLATE FIN COIL
	NOM. AIRFLOW l/s		1250	1670	1750	1985	2235
	EXT STATIC pa		100 (ALL FANS ARE HIGH STATIC FANS. REFER TO FAN CURVES.)				
	DIMENSIONS						
	H X W X D (mm)		1195 x 1600 x 1100				
	WEIGHT						
	OPERATING KG		201	204	204	233	233
	SHIPPING KG		205	208	208	237	237
ELECTRICAL							
POWER SUPPLY		415v / 3Ø / 50hz					
FLA/RLA (Amps)		4.2/1.0	4.2/1.2	4.2/1.3	4.6/1.3	4.6/1.7	
COMBINED SECTIONS	ELECTRICAL						
	H.P. CUT OUT / IN kPa		4500 / 3450	4500 / 3450	4500 / 3450	4500 / 3450	4500 / 3450
	L.P. CUT OUT / IN kPa		175 / 345	175 / 345	175 / 345	175 / 345	175 / 345
	NOM. R.L.A. (TOTAL SYSTEM)		13.6	15.9	19.4	20.7	23.0
	MAX. F.L.A. (TOTAL SYSTEM)		23.8	28.4	31.4	39.8	39.8
	GENERAL						
	CABINET GALVANISED SHEET STEEL						
	INSULATION ALUMINIUM FOIL FACED POLYETHYLENE ACOUSTIC INSULATION (Indoor Only)						
	EXTERNAL FINISH POLYESTER POWDER COAT - COLOUR LIGHT GREY AS STANDARD - OPTIONS AVAILABLE						
	INDOOR AND OUTDOOR PIPE CONNECTION						
	LIQUID mm (inch)		9.5 (3/8")	9.5 (3/8")	9.5 (3/8")	9.5 (3/8")	9.5 (3/8")
	GAS MM (inch)		19.1 (3/4")	19.1 (3/4")	19.1 (3/4")	22.2 (7/8")	22.2 (7/8")
ADDITIONAL REFRIGERATION CHARGE AND FIELD PIPING CONNECTION							
REFER TO INSTALLATION AND OPERATION MANUAL							
NOISE LEVELS [Based on condenser fan's sound data]							
Sound Power db(A)		66.5	66.5	66.5	66.3	66.3	

Note: Rated in accordance with Australian standard AS/NZS 3823.1:2012
 Performance excludes ikW of evaporator fan motor.
 R.L.A - Run Load Amps are based on current drawn at nominal conditions
 F.L.A - Full Load Amps are based on the overload settings [Max Current] of all Compressor and Fan Motor(s).

Date	Document #	Approved By	Revision
1/6/18	TDS0027	CM	D

NOTE: Due to continuous improvement Rinnai Australia Pty Ltd reserve the right to change details without notice.

FAN PERFORMANCE CURVE

S030IHR3SA-

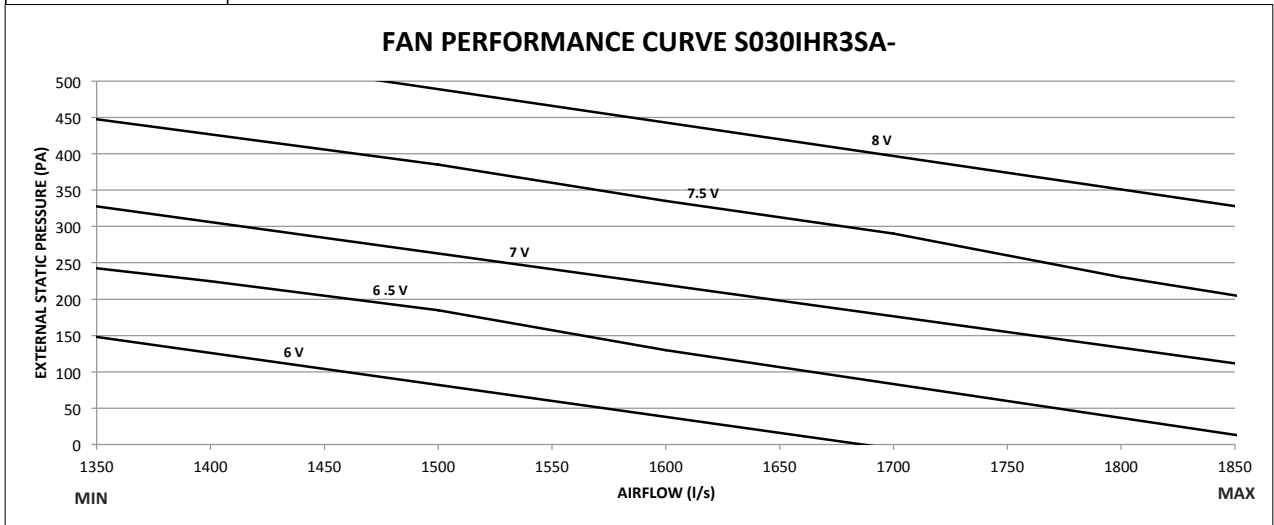

Note:

1. 6V, 6.5V, 7V, 7.5V and 8V represents potentiometer voltage. Potentiometer can be adjusted to achieve desired flowrates.
2. Potentiometer voltage can be varied infinitely between 0 to 10V.

Date	Document #	Approved By	Revision
29.05.18	FPC0034	CM	B

NOTE: Due to continuous improvement Rinnai Australia Pty Ltd reserve the right to change details without notice.



SOUND DATA

MODEL NUMBER

S030IHR3SA- / S030OVR3SA-

Outdoor Fan

Sound Power Level dB(A)	Octave band Centre Frequency (Hz), dB						
	125	250	500	1k	2k	4k	8k
66.5	72.2	61.6	61.9	61.8	59.8	52.9	50.1

Indoor Fan

Sound Power Level dB(A)	Air Flow (l/s)	Octave band Centre Frequency (Hz), dB						
		125	250	500	1k	2k	4k	8k
80.4	1600	62.8	72.6	75.6	76.3	72	71.2	71.2

Date	Document #	Approved By	Revision
01.06.18	SD0020	CM	B

NOTE: Due to continuous improvement Rinnai Australia Pty Ltd reserve the right to change details

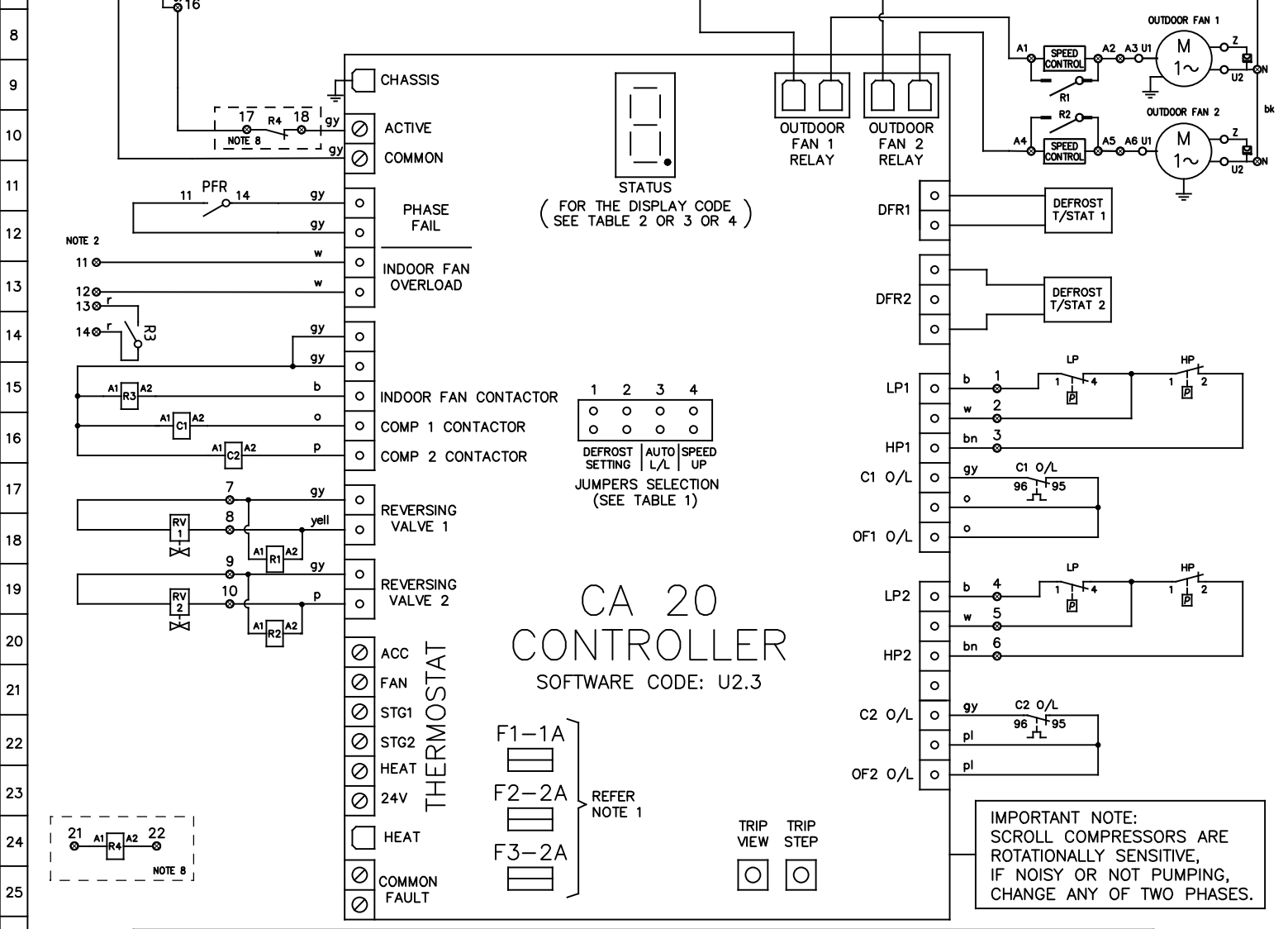
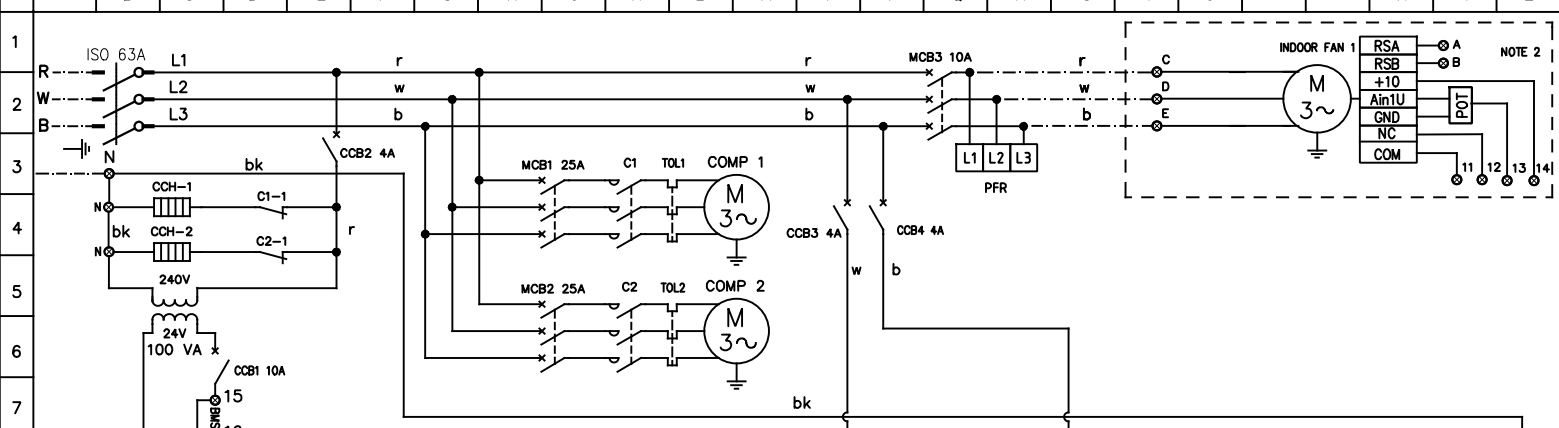

CA 20 CONTROLLER

SOFTWARE CODE: U2.3

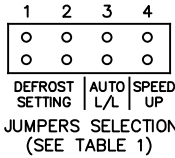

IMPORTANT NOTE:
SCROLL COMPRESSORS ARE ROTATIONALLY SENSITIVE, IF NOISY OR NOT PUMPING, CHANGE ANY OF TWO PHASES.

WARNING! THE SOFTWARE OF THE CA20 CONTROLLER IS NOT DESIGNED TO FUNCTION AS A PRIMARY PERSONAL SAFETY DEVICE, AS CONNECTED EQUIPMENT CAN START AUTOMATICALLY WITHOUT WARNING. ALSO, OPENING THERMOSTAT CONTACTS MAY NOT CAUSE THE EQUIPMENT TO STOP. OUTDOOR FAN MOTORS HAVE INTERNAL OVERLOADS AND MAY RESTART AUTOMATICALLY.

- NOTES:
- TIME DELAY GLASS FUSES ON THE PCB CONTROLLER ARE THE FOLLOWING:
 - F1 PROTECTS THE THERMOSTAT CIRCUIT.
 - F2 PROTECTS THE REVERSING VALVE CIRCUITS AND THE "HEAT" OUTPUT. THIS FUSE F2 ALSO SUPPLIES FUSE F1.
 - F3 PROTECTS BOTH COMPRESSOR CONTACTOR CIRCUITS AND THE INDOOR FAN CONTACTOR CIRCUIT.
 - FOR SPLIT SYSTEMS. OTHERS TO INSTALL ISOLATOR AND FIELD WIRING
 - HP CUT OUT & LP CUT OUT - AUTO RESET.
 - THERMAL OVERLOAD RELAYS - AUTO RESET, UNLESS OTHERWISE STATED.
 - DO NOT CONNECT ANY ADDITIONAL EQUIPMENT TO THE CONTROL TRANSFORMER OTHER THAN THE EQUIPMENT SHOWN ON THE ELECTRICAL DRAWING.
 - ALL FIELD WIRING IS THE RESPONSIBILITY OF THE INSTALLING CONTRACTOR AND MUST COMPLY WITH AS/NZS 3000 AND LOCAL RULES.
 - SOFTWARE CODE MUST BE CHECKED AFTER REPLACEMENT OF THE CA-20 CONTROLLER BY CHECKING THE DISPLAY CODE ON THE 7 SEGMENT DISPLAY AFTER THE CONTROLLER IS ACTIVATED.
 - OPTIONAL FIRE ALARM RELAY

JUMPERS SELECTION	DEFROST INTERVAL TIME SETTING	JUMPERS SELECTION	AUTO LEAD/LAG	JUMPERS SELECTION	SPEED UP										
<table border="1" style="font-size: small;"> <tr><td>1</td><td>2</td></tr> <tr><td>○</td><td>○</td></tr> <tr><td>○</td><td>○</td></tr> </table>	1	2	○	○	○	○	15 min	<table border="1" style="font-size: small;"> <tr><td>3</td></tr> <tr><td>○</td></tr> </table>	3	○	OFF	<table border="1" style="font-size: small;"> <tr><td>4</td></tr> <tr><td>○</td></tr> </table>	4	○	OFF
1	2														
○	○														
○	○														
3															
○															
4															
○															
<table border="1" style="font-size: small;"> <tr><td>1</td><td>2</td></tr> <tr><td>○</td><td>○</td></tr> <tr><td>○</td><td>○</td></tr> </table>	1	2	○	○	○	○	FACTORY SETTING 30 min	<table border="1" style="font-size: small;"> <tr><td>3</td></tr> <tr><td>○</td></tr> </table>	3	○	ON	<table border="1" style="font-size: small;"> <tr><td>4</td></tr> <tr><td>○</td></tr> </table>	4	○	ON
1	2														
○	○														
○	○														
3															
○															
4															
○															
<table border="1" style="font-size: small;"> <tr><td>1</td><td>2</td></tr> <tr><td>○</td><td>○</td></tr> <tr><td>○</td><td>○</td></tr> </table>	1	2	○	○	○	○	45 min	<table border="1" style="font-size: small;"> <tr><td>3</td></tr> <tr><td>○</td></tr> </table>	3	○	ON	<table border="1" style="font-size: small;"> <tr><td>4</td></tr> <tr><td>○</td></tr> </table>	4	○	ON
1	2														
○	○														
○	○														
3															
○															
4															
○															

UNIT MUST BE SWITCHED OFF BEFORE CHANGING THE JUMPER SELECTION

LEGEND		LEGEND		COLOUR CODE		COMPRESSOR (EACH)		MODEL: S0300VR3SA-H	
○	TERMINAL SWITCHBOARD	TOL	THERMAL OVERLOAD RELAY	r	RED	KW	3.59	OPTIONS DESCRIPTION	
⊗	TERMINAL	C	CONTACTOR	w	WHITE	RATED CURRENT	10.30		
---	FIELD WIRING	bk	CONTACTOR OF OUTDOOR FAN	b	BLUE	O/L SETTING	11.50	STANDARD	
---	CONTROL PARAMETER	bn	COMPRESSOR ISOLATOR SWITCH	br	BROWN	FANS (EACH) KW	FLA		
---	MAINS/CONTROL WIRING	o	MINIATURE CIRCUIT BREAKER	o	ORANGE	OUTDOOR	0.39	1.78	
---	CCH CRANK CASE HEATER	p	CONTROL CIRCUIT BREAKER	p	PINK	INDOOR	2.73	4.20	
---	PFR PHASE FAILURE RELAY	pl	CONTROL CIRCUIT BREAKER	pl	PURPLE				
---	RV REVERSING VALVE	gy	OVERLOAD	gy	GREY				
---	HP HIGH PRESSURE SWITCH	yell	POTENTIOMETER	yell	YELLOW				
---	LP LOW PRESSURE SWITCH	POT							

apac
by Riinnai

DATE		24/06/2018	
DWN	S.P	APPD	ENG
REV	A	GRID	B156
DWG No.	EWS02137		