



**HPU HANDING CONFIRMATION**

<b>SO NUMBER</b> (INTERNAL USE)		<b>WO NUMBER</b> (INTERNAL USE)	
------------------------------------	--	------------------------------------	--

**ROOF TOP PACKAGED UNITS (RTU)**

<b>MODELS</b>	All
<b>GENERAL</b>	This document details the airside configurations available on all HPU models.
<b>SOURCING</b>	Standard configuration is detailed in the unit general arrangement drawings. Optional airside configurations to be specified at time of order.
<b>HOW TO USE THIS DOCUMENT</b>	<ol style="list-style-type: none"> <li>1. Choose if the supply air fan position is required on the left or right.</li> <li>2. Circle the required supply air outlet.</li> <li>3. Circle the required return air inlet.</li> <li>4. Complete the information at the bottom of this document and return to your APAC representative.</li> </ol>

LEFT HAND SUPPLY AIR (STANDARD)	RIGHT HAND SUPPLY AIR (OPTIONAL)
---------------------------------	----------------------------------

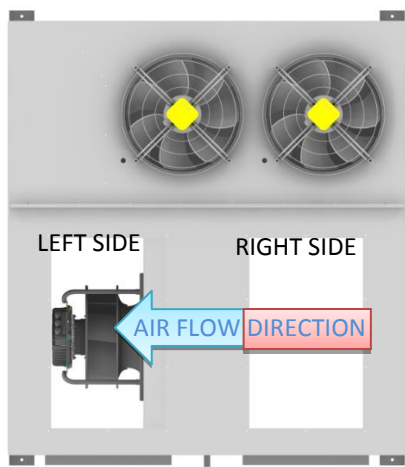

Fig1. Left hand unit from the top view

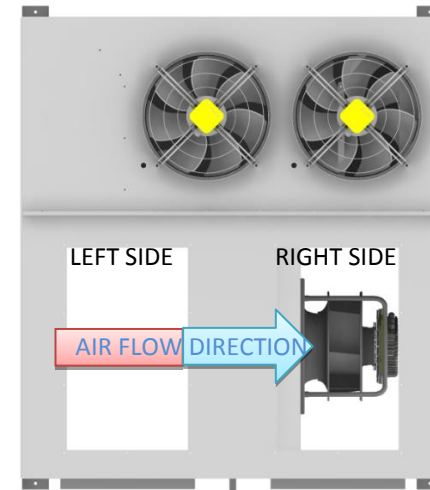

Fig3. Right hand unit from top view

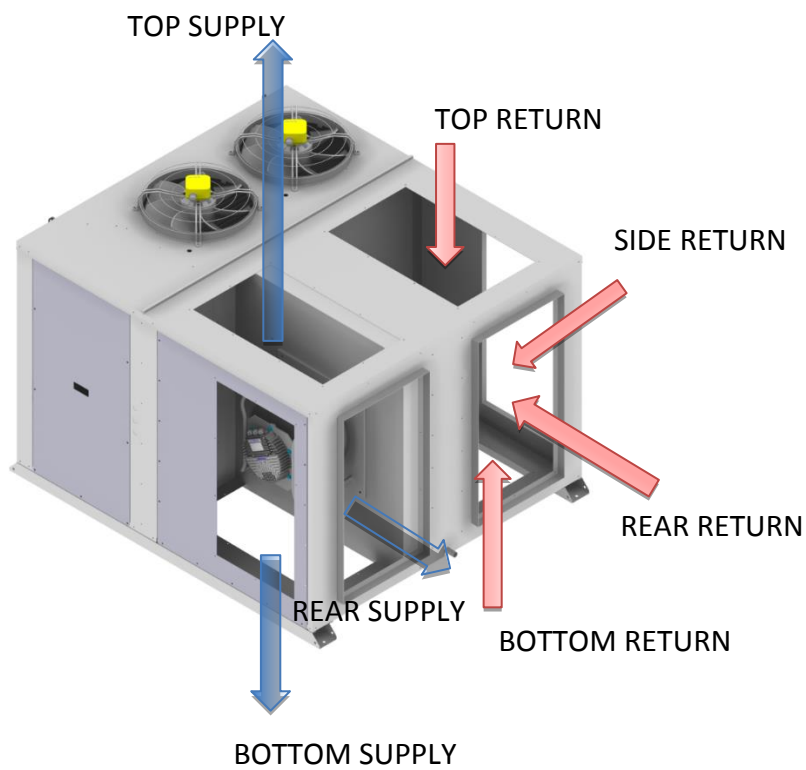

Fig2. Air flow schematic of the left hand unit

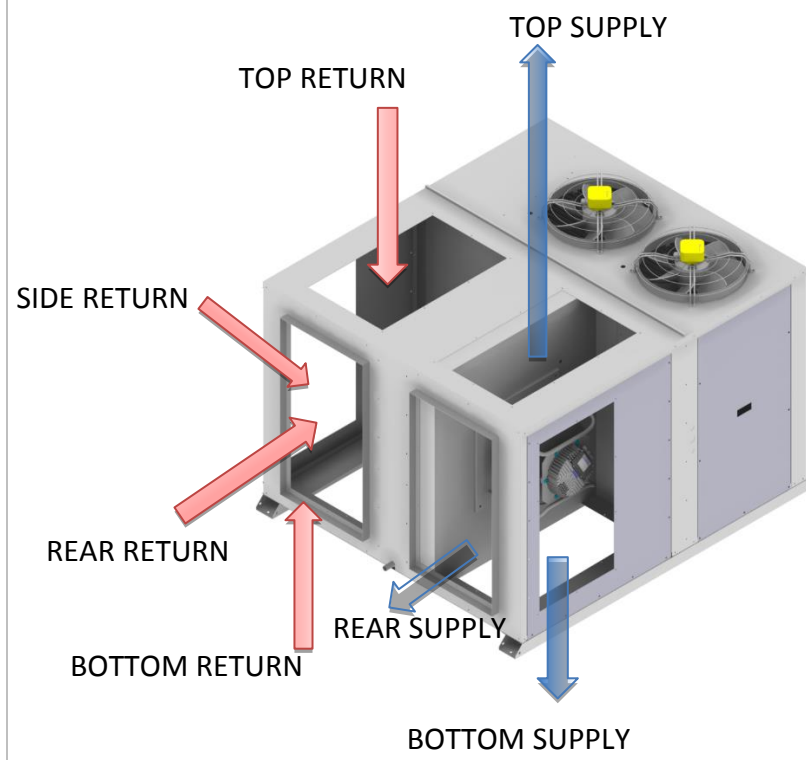
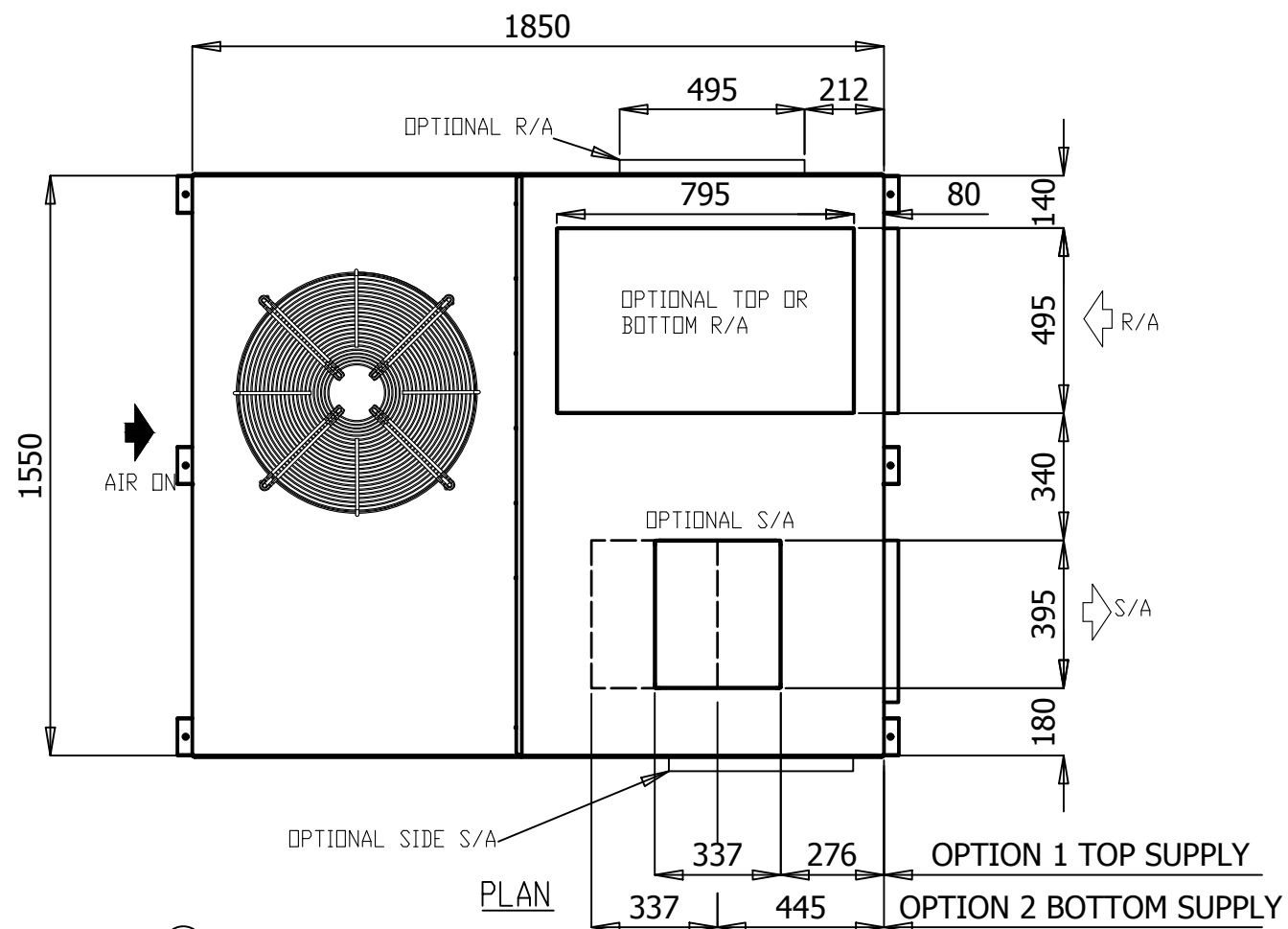

Fig 4. Air flow schematic of the right hand unit

**CUSTOMER TO COMPLETE AND RETURN**

CUSTOMER	PROJECT	UNIT REF	NAME / SIGN	DATE



- NOTES:
1. GENERAL ARRANGEMENT OF A HORIZONTAL AIR COOLED PACKED UNIT
  2. POWER AND FIELD CABLE ENTRIES, 1 x 32 $\phi$  AND 2 x 25 $\phi$
  3. ELECTRICAL PANEL LOCATED BEHIND SERVICE ACCESS
  4. CONDENSATE OUTLET 25 $\phi$
  5. UNIT BASE 6 x 12 $\phi$  FIXING POINTS
  6. UNIT HAS 4 x 12 $\phi$  LIFTING POINTS
  7. UNIT CONFIGURATION AS STANDARD IS REAR LEFT SUPPLY, REAR RIGHT RETURN, OTHER CONFIGURATIONS AVAILABLE.
  8. UNIT CONFIGURATION CAN BE CONVERTED IN FIELD WITH OPTIONAL ACCESSORIES.

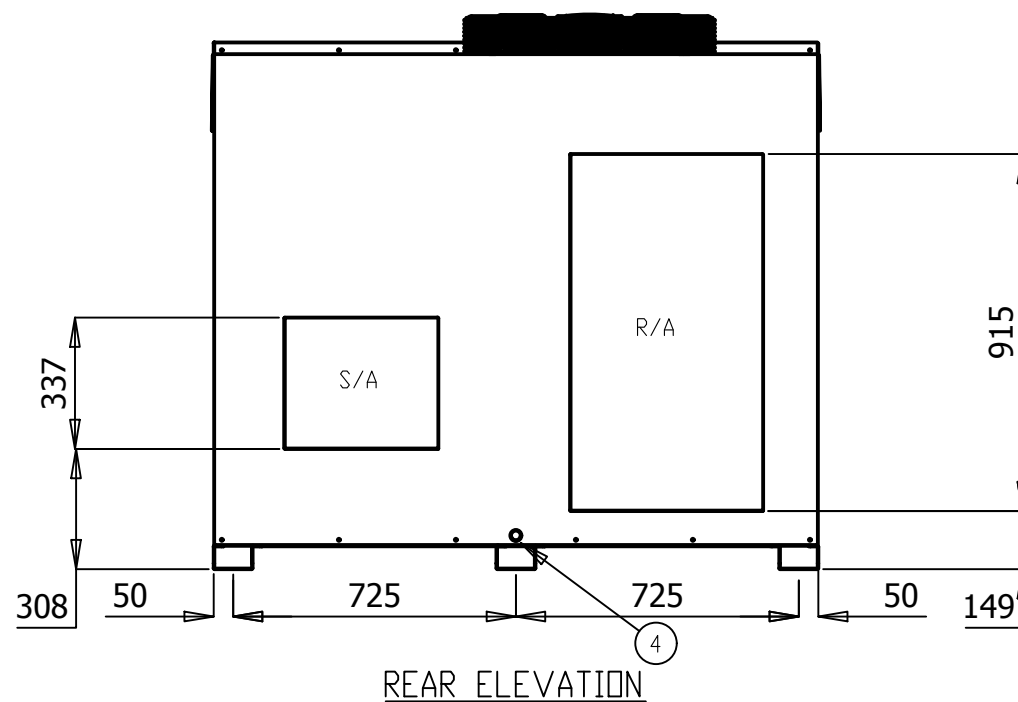
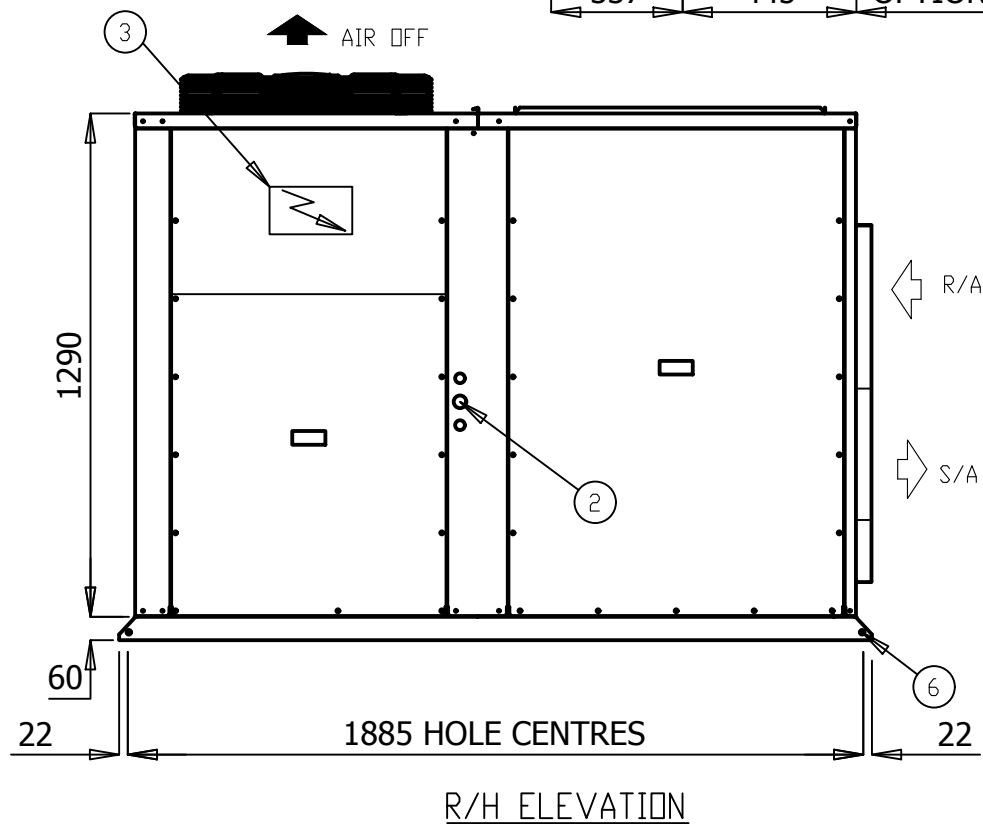
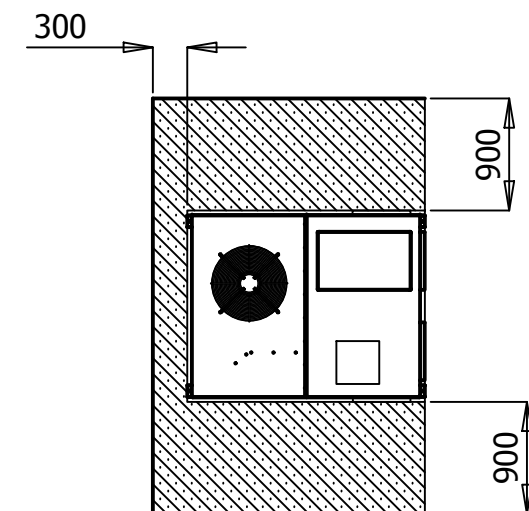

CLEARANCE DETAIL

REAR ELEVATION

- ALL DIMENSIONS IN mm.
- GENERAL TOLERANCE  $\pm 1$ mm.
- DO NOT SCALE DRAWING.
- MASTER DRAWINGS ARE HELD ELECTRONICALLY. ANY COPY IS DEEMED UNCONTROLLED AND THEREFORE NOT NECESSARILY THE LATEST REVISION.
- ALL INFORMATION REMAINS THE PROPERTY OF THE COMPANY.

## GENERAL ARRANGEMENT

P028AHR3SA-

www.apacair.com.au

ABN: 74 005 138 769

REVISION	REVISED NAMEPLATE WITH APAC DETAILS				
		DRAWN	MT	DRAWING No.	A4
	ATLANTIC DR. KEYSBOROUGH VIC 3173 1300 555 545	DATE	26.03.17	<b>GAD0079</b>	
	SCALE	N.T.S.			
	CHECKED	HA	APP'D.	CM	REV.



# TECHNICAL DATA SHEET

MODEL NUMBER		P028AHR3SA-	P033AHR3SA-	P038AHR3SA-	P043AHR3SA-	P048AHR3SA-	
MEPS REGISTRATION NUMBER		AAC3205	AAC3214	AAC3200	AAC3280	AAC3282	
CONDENSER SECTION	<b>CAPACITY</b>						
	Cooling	kW TOTAL*	28.10	32.30	37.60	42.21	45.84
		kW SENSIBLE*	22.89	26.65	30.42	34.70	38.09
		EER (kW / ikW)*	3.21	3.25	3.30	3.20	3.16
	Heating	kW TOTAL	28.48	33.00	39.58	43.93	47.48
		COP	3.60	3.67	3.66	3.62	3.65
	CAPACITY STEPS (%)		50/100	50/100	50/100	50/100	50/100
	<b>COMPRESSOR</b>						
	TYPE		TANDEM SCROLL	TANDEM SCROLL	TANDEM SCROLL	TANDEM SCROLL	TANDEM SCROLL
	STARTER TYPE		D.O.L (Opt Soft/Start)	D.O.L (Opt Soft/Start)	D.O.L (Opt Soft/Start)	D.O.L (Opt Soft/Start)	D.O.L (Opt Soft/Start)
	PHASE		3Ø	3Ø	3Ø	3Ø	3Ø
	No. OFF		1	1	1	1	1
	PROTECTION DEVICES		HP SWITCH, LP SWITCH, MOTOR OVERLOAD'S				
	ALL COMPRESSORS HAVE		CRANKCASE HEATER				
	<b>FAN</b>						
	TYPE		AXIAL	AXIAL	AXIAL	AXIAL	AXIAL
	ikW (MAX INPUT)		0.97	0.93	0.93	0.93	0.93
	PHASE		3Ø	3Ø	3Ø	3Ø	3Ø
	No. OFF		1	1	1	1	1
	FAN SPEED CONTROL		VARIABLE SPEED	VARIABLE SPEED	VARIABLE SPEED	VARIABLE SPEED	VARIABLE SPEED
	<b>HEAT EXCHANGER</b>						
TYPE		PLATE FIN COIL	PLATE FIN COIL	PLATE FIN COIL	PLATE FIN COIL	PLATE FIN COIL	
NOM. AIRFLOW l/s		-	-	-	-	-	
<b>REFRIGERANT SYSTEM</b>							
TYPE		<b>R410A</b>					
CHARGE PER CIRCUIT (KG)		5.75	6.75	9.5	11	10.8	
No. OF CIRCUITS		1	1	1	1	1	
REFRIGERANT CONTROL		TXV					
ALL SYSTEMS INCLUDE		DRIERS & SIGHT GLASSES					
EVAPORATOR SECTION	<b>FAN</b>						
	TYPE		CENTRIFUGAL	CENTRIFUGAL	CENTRIFUGAL	CENTRIFUGAL	CENTRIFUGAL
	ikW (MAX INPUT)		2.73	2.73	2.73	2.82	2.82
	PHASE		3Ø	3Ø	3Ø	3Ø	3Ø
	No. OFF		1	1	1	1	1
	FAN SPEED CONTROL		VARIABLE SPEED	VARIABLE SPEED	VARIABLE SPEED	VARIABLE SPEED	VARIABLE SPEED
	<b>HEAT EXCHANGER</b>						
	TYPE		PLATE FIN COIL	PLATE FIN COIL	PLATE FIN COIL	PLATE FIN COIL	PLATE FIN COIL
NOM. AIRFLOW l/s		1450	1775	1875	2200	2470	
EXT STATIC pa		100					
COMBINED SECTIONS	<b>ELECTRICAL</b>						
	MAINS POWER		415v / 3Ø / 50hz	415v / 3Ø / 50hz	415v / 3Ø / 50hz	415v / 3Ø / 50hz	415v / 3Ø / 50hz
	H.P. CUT OUT / IN kPa		4500 / 3450	4500 / 3450	4500 / 3450	4500 / 3450	4500 / 3450
	L.P. CUT OUT / IN kPa		175 / 345	175 / 345	175 / 345	175 / 345	175 / 345
	NOM. R.L.A. (TOTAL SYSTEM)		16.1	17.3	19.8	22.7	26.6
	MAX. F.L.A. (TOTAL SYSTEM)		26.8	29.3	35.7	35.8	38.2
	<b>GENERAL</b>						
	CABINET		GALVANISED SHEET STEEL				
	INSULATION		ALUMINIUM FOIL FACED POLYETHYLENE ACOUSTIC INSULATION				
	EXTERNAL FINISH		POLYESTER POWDER COAT - COLOUR LIGHT GREY AS STANDARD - OPTIONS AVAILABLE				
	<b>DIMENSIONS</b>						
	H X W X D (mm)		1350 x 1550 x 1850	1555 x 1550 x 1850		1760 x 1550 x 1850	
	<b>WEIGHT</b>						
	OPERATING KG		425	470	490	540	570
SHIPPING KG		430	475	495	545	575	
<b>NOISE LEVELS [Based on condenser fan's sound data]</b>							
Sound Power db(A)		67.9	68.5	68.5	68.5	68.5	

**Note:** Rated in accordance with Australian standard AS/NZS 3823.1:2012  
 Performance excludes ikW of evaporator fan motor.  
 R.L.A - Run Load Amps are based on current drawn at nominal conditions  
 F.L.A - Full Load Amps are based on the overload settings [Max Current] of all Compressor and Fan Motor(s).

Date	Document #	Approved By	Revision
1/6/18	TDS0034	CM	B

**NOTE:** Due to continuous improvement Rinnai Australia Pty Ltd reserve the right to change details without notice.

## FAN PERFORMANCE CURVE

**P028AHR3SA-**

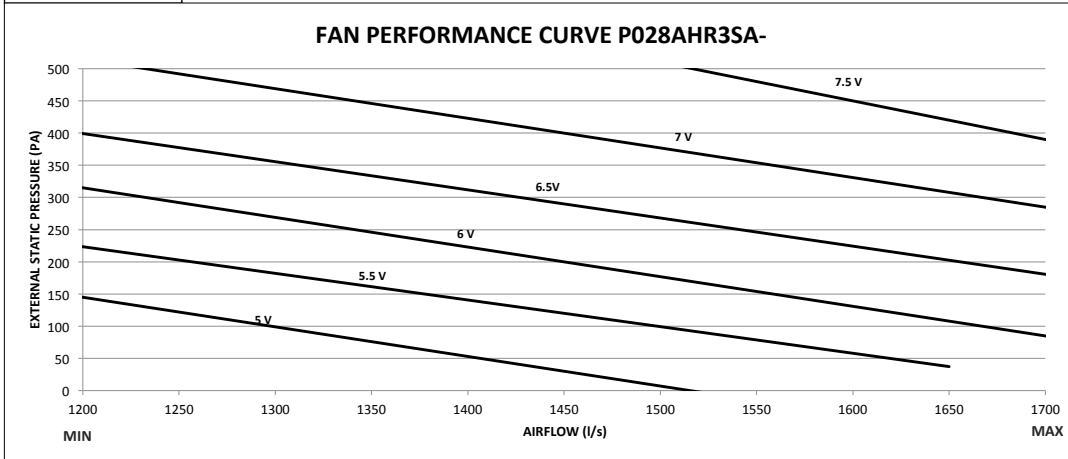

Note:

1. 4V, 4.5V, 5V, 5.5V, 6V, 6.5 V, 7V and 7.5 V represents potentiometer voltage. Potentiometer can be adjusted to achieve desired flowrates.
2. Potentiometer voltage can be varied infinitely between 0 to 10V.

Date	Document #	Approved By	Revision
30.05.18	FPC0061	CM	B

**NOTE: Due to continuous improvement Rinnai Australia Pty Ltd reserve the right to change details without notice.**



## SOUND DATA

**MODEL NUMBER**

**P028AHR3SA-**

**Outdoor Fan**

Sound Power Level dB(A)	Octave band Centre Frequency (hz), dB						
	125	250	500	1k	2k	4k	8k
67.9	71.1	63.2	64.9	62	60.1	58.4	55.2

**Indoor Fan**

Sound Power Level dB(A)	Air Flow (l/s)	Octave band Centre Frequency (hz), dB						
		125	250	500	1k	2k	4k	8k
79.1	1444	61.9	71.3	74.8	75.2	71	69	67.8

Date	Document #	Approved By	Revision
02.06.18	SD0049	CM	B

**NOTE: Due to continuous improvement Rinnai Australia Pty Ltd reserve the right to change details**

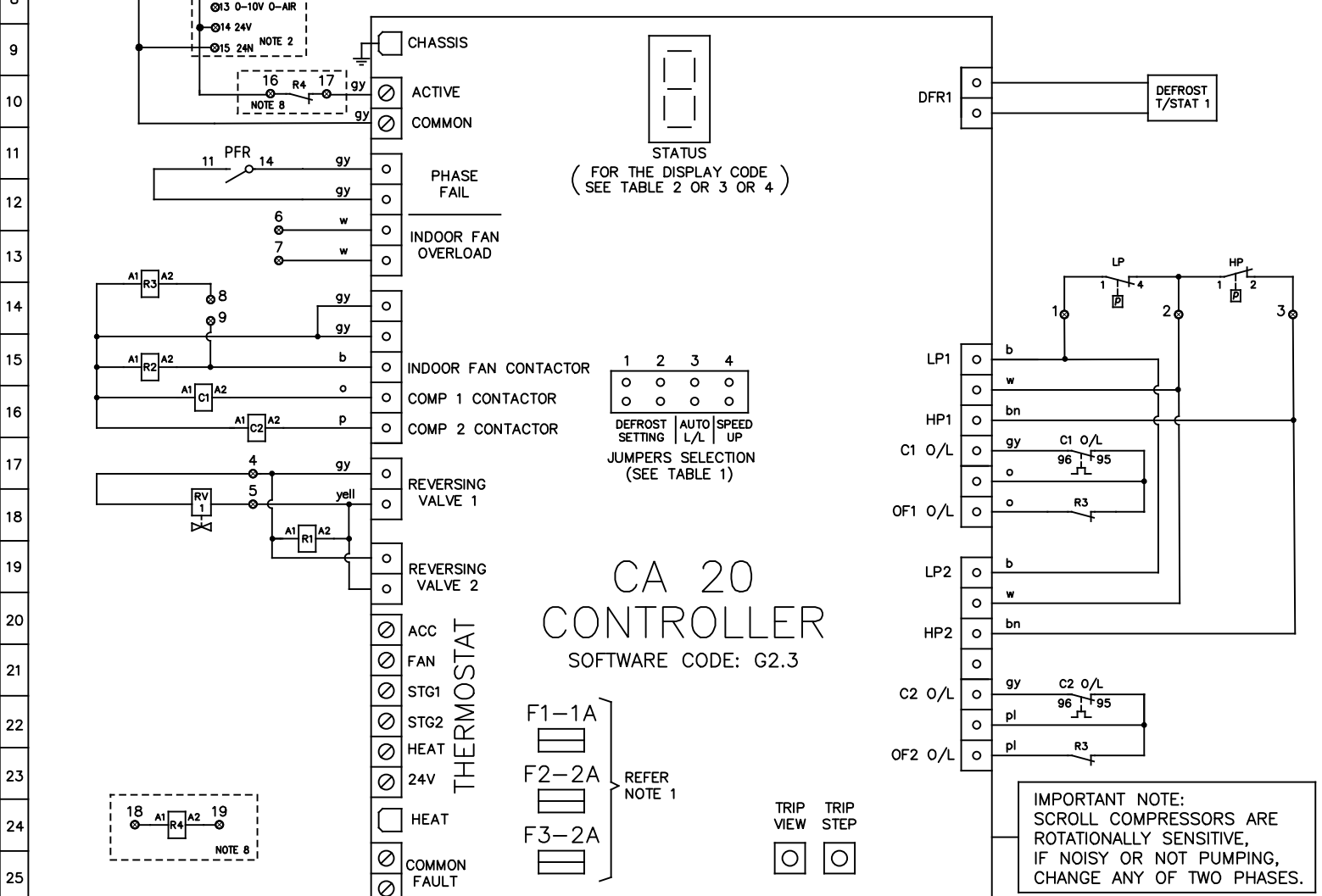
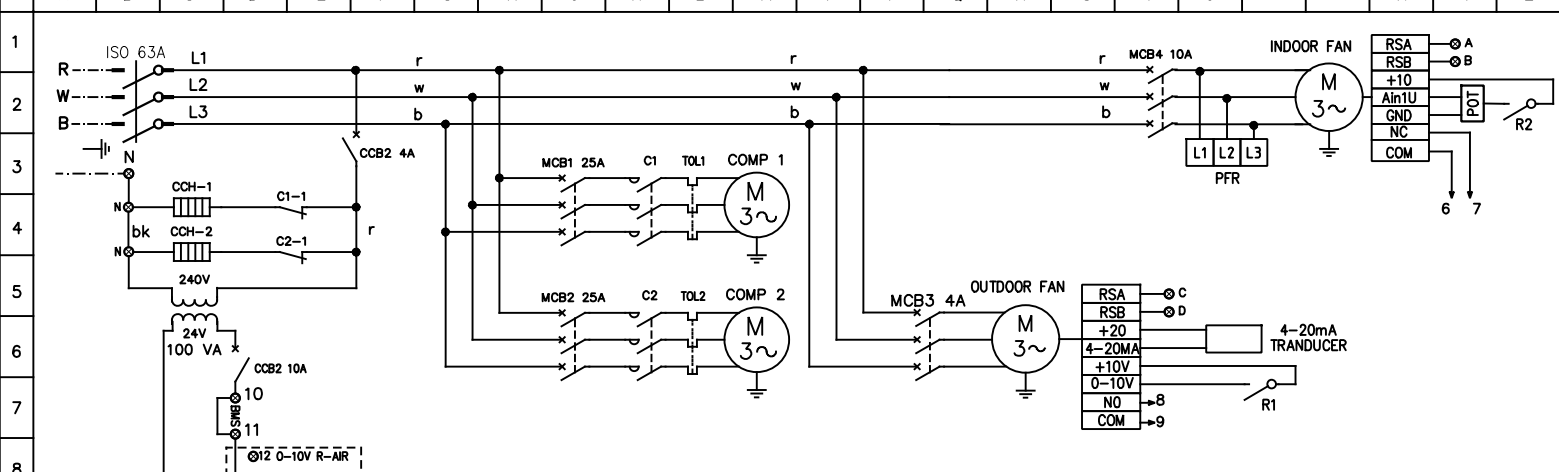

# CA 20 CONTROLLER

SOFTWARE CODE: G2.3

**IMPORTANT NOTE:**  
SCROLL COMPRESSORS ARE ROTATIONALLY SENSITIVE, IF NOISY OR NOT PUMPING, CHANGE ANY OF TWO PHASES.

**WARNING!** THE SOFTWARE OF THE CA20 CONTROLLER IS NOT DESIGNED TO FUNCTION AS A PRIMARY PERSONAL SAFETY DEVICE, AS CONNECTED EQUIPMENT CAN START AUTOMATICALLY WITHOUT WARNING. ALSO, OPENING THERMOSTAT CONTACTS MAY NOT CAUSE THE EQUIPMENT TO STOP. OUTDOOR FAN MOTORS HAVE INTERNAL OVERLOADS AND MAY RESTART AUTOMATICALLY.

- NOTES:
1. TIME DELAY GLASS FUSES ON THE PCB CONTROLLER ARE THE FOLLOWING:
    - F1 PROTECTS THE THERMOSTAT CIRCUIT.
    - F2 PROTECTS THE REVERSING VALVE CIRCUITS AND THE "HEAT" OUTPUT. THIS FUSE F2 ALSO SUPPLIES FUSE F1.
    - F3 PROTECTS BOTH COMPRESSOR CONTACTOR CIRCUITS AND THE INDOOR FAN CONTACTOR CIRCUIT.
  2. OPTIONAL 24VAC POWER SUPPLY AND 0-10V TERMINALS FOR ECONOMY CYCLE DAMPER MOTORS
  3. HP CUT OUT , LP CUT OUT - AUTO RESET.
  4. THERMAL OVERLOAD RELAYS - AUTO RESET, UNLESS OTHERWISE STATED.
  5. DO NOT CONNECT ANY ADDITIONAL EQUIPMENT TO THE CONTROL TRANSFORMER OTHER THAN THE EQUIPMENT SHOWN ON THE ELECTRICAL DRAWING.
  6. ALL FIELD WIRING IS THE RESPONSIBILITY OF THE INSTALLING CONTRACTOR AND MUST COMPLY WITH AS/NZS 3000 AND LOCAL RULES.
  7. SOFTWARE CODE MUST BE CHECKED AFTER REPLACEMENT OF THE CA-20 CONTROLLER BY CHECKING THE DISPLAY CODE ON THE 7 SEGMENT DISPLAY AFTER THE CONTROLLER IS ACTIVATED.
  8. OPTIONAL FIRE ALARM RELAY

JUMPERS SELECTION	DEFROST INTERVAL TIME SETTING	JUMPERS SELECTION	AUTO LEAD/LAG	JUMPERS SELECTION	SPEED UP										
<table border="1"> <tr><td>1</td><td>2</td></tr> <tr><td>o</td><td>o</td></tr> <tr><td>o</td><td>o</td></tr> </table>	1	2	o	o	o	o	15 min	<table border="1"> <tr><td>3</td></tr> <tr><td>o</td></tr> </table>	3	o	OFF	<table border="1"> <tr><td>4</td></tr> <tr><td>o</td></tr> </table>	4	o	OFF
1	2														
o	o														
o	o														
3															
o															
4															
o															
<table border="1"> <tr><td>1</td><td>2</td></tr> <tr><td>o</td><td>o</td></tr> <tr><td>o</td><td>o</td></tr> </table>	1	2	o	o	o	o	FACTORY SETTING 30 min	<table border="1"> <tr><td>3</td></tr> <tr><td>o</td></tr> </table>	3	o	ON	<table border="1"> <tr><td>4</td></tr> <tr><td>o</td></tr> </table>	4	o	ON
1	2														
o	o														
o	o														
3															
o															
4															
o															
<table border="1"> <tr><td>1</td><td>2</td></tr> <tr><td>o</td><td>o</td></tr> <tr><td>o</td><td>o</td></tr> </table>	1	2	o	o	o	o	45 min								
1	2														
o	o														
o	o														

UNIT MUST BE SWITCHED OFF BEFORE CHANGING THE JUMPER SELECTION

LEGEND		LEGEND		COLOUR CODE		COMPRESSOR (EACH)		MODEL: P028AHR3SA	
o	TERMINAL SWITCHBOARD	TOL	THERMAL OVERLOAD RELAY	r	RED	KW	3.59	OPTIONS	
o	TERMINAL	R	CONTACTOR	w	WHITE	RATED CURRENT	10.30	DESCRIPTION	
o	FIELD WIRING	C	OUTDOOR FAN	b	BLUE	O/L SETTING	11.50	STANDARD	
o	CONTROL PARAMETER	COMP	COMPRESSOR	bk	BLACK	FANS (EACH)	KW	FLA	
o	MAINS/CONTROL WIRING	ISO	ISOLATOR SWITCH	bn	BROWN	OUTDOOR	0.97	1.60	
o	CCH	MCB	MINIATURE CIRCUIT BREAKER	o	ORANGE	INDOOR	2.73	4.20	
o	PFR	CCB	CONTROL CIRCUIT BREAKER	p	PINK				
o	RV	CCB	CONTROL CIRCUIT BREAKER	pl	PURPLE				
o	HP	O/L	OVERLOAD	gy	GREY				
o	LP	POT	POTENTIOMETER	yell	YELLOW				

DATE: 24/06/2018

DWN: S.P    APPD: ENG

REV: A    GRID: B28

DWG No: EWS02025